

TruckFIT 800

Vane Pump with Integral Multi-Way Valve

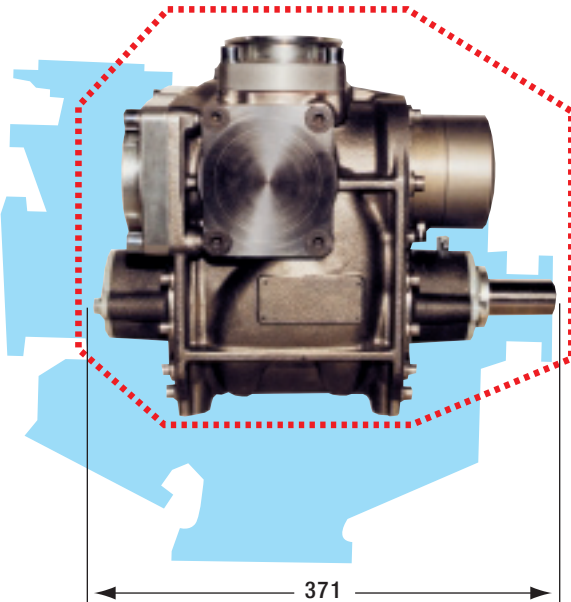

Alfons Haar



Fits any truck chassis frame!

VANE PUMP

- Compact design
- Blow-down for product change
- Self-priming

Multi-way valve pneumatically operated, continuous flow control via by-pass valve.

Smooth performance!

40-years of experience and computer aided hydrodynamic flow makes the vane pump whisper.

The high efficiency of the TruckFIT 800 reduces fuel consumption and engine emissions by up to 50%.

Full hose delivery at idle speed.

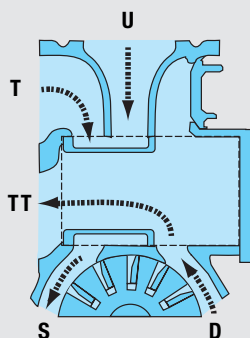
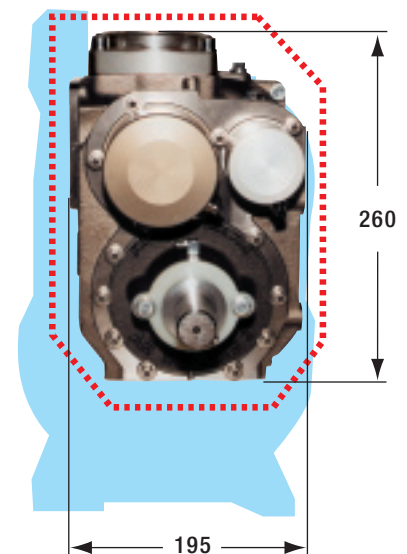

SELF-LOADING
From trailer or external tank

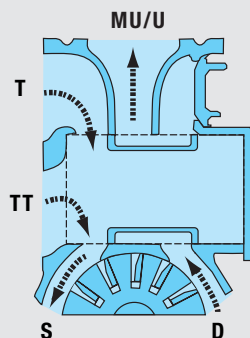

PUMPED DELIVERY
From tank or trailer

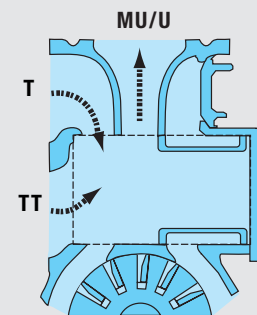

GRAVITY DISCHARGE
From tank or trailer

TruckFIT 800

Vane Pump with Integral Multi-Way Valve

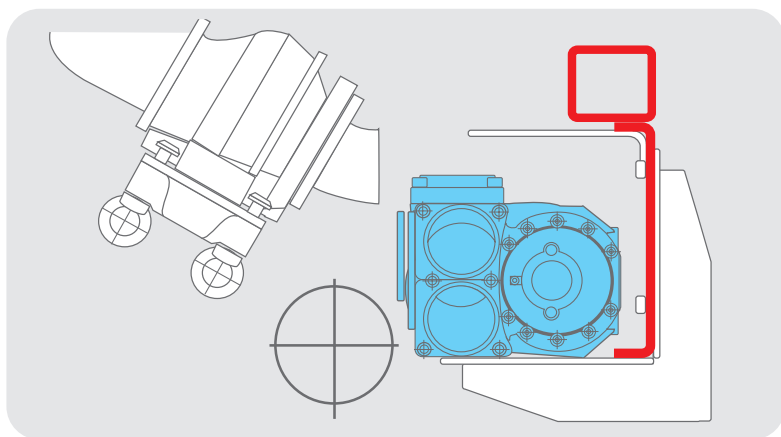
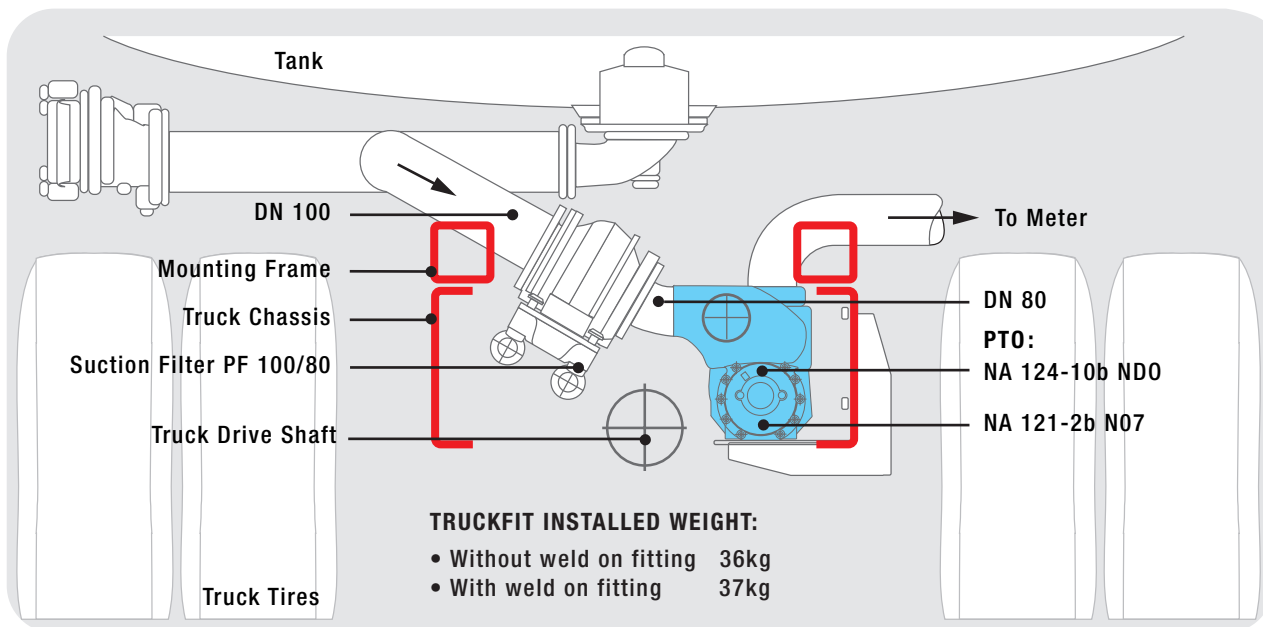

TRUCKFIT PERFORMANCE DIAGRAM

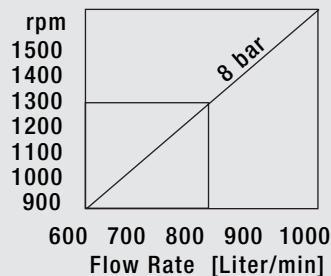

TRUCKFIT CAN ALSO OPERATE WITH MEASURING UNITS: PRECIMA 500 + 800

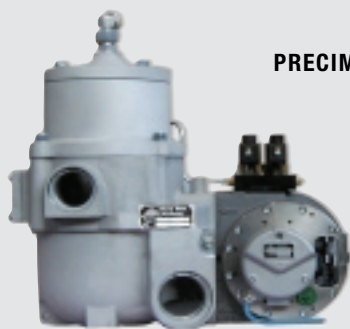

PRECIMA 500

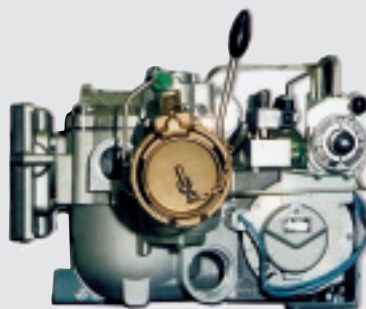

PRECIMA 800

- 800 l/min
- Wet hose
- and dry hose