

SELF-PRIMING VANE PUMP

Depending on selected pump version up to 4000 l/min with $\Delta p = 8$ bar



Product shown with optional accessoires

Ex II 2G cT3 CE certified.
Operation without a flame arrestor is possible in compliance with the certified ATEX conditions.

Optional drives: integrated hydraulic (as shown), prop shaft, electric motor

FEATURES

- High efficiency
- Low noise emission
- Small body
- Light weight

By current modelling using numerical methods

- Pneumatic (remote controllable) or wire spring bypass valve

FPQ 150

REFUELLER VANE PUMP



DIMENSIONS

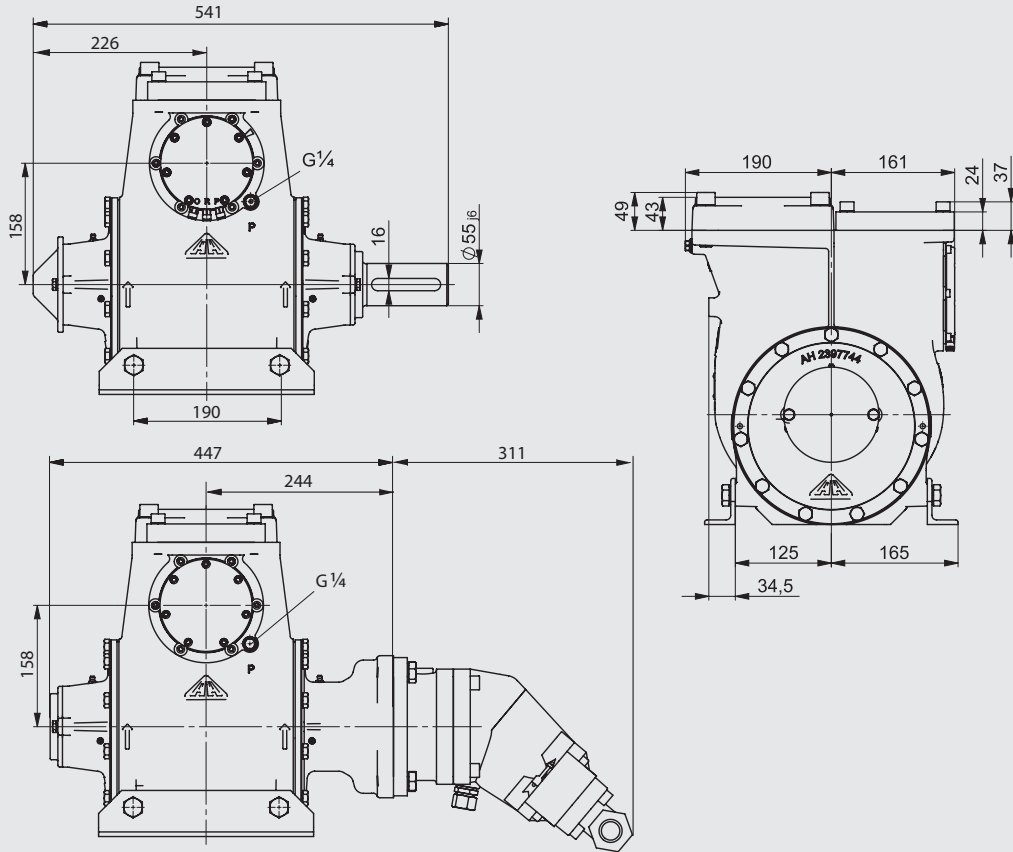

FLOW RATE

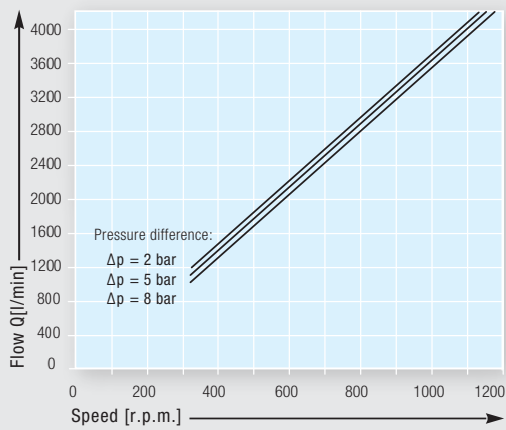

POWER CONSUMPTION

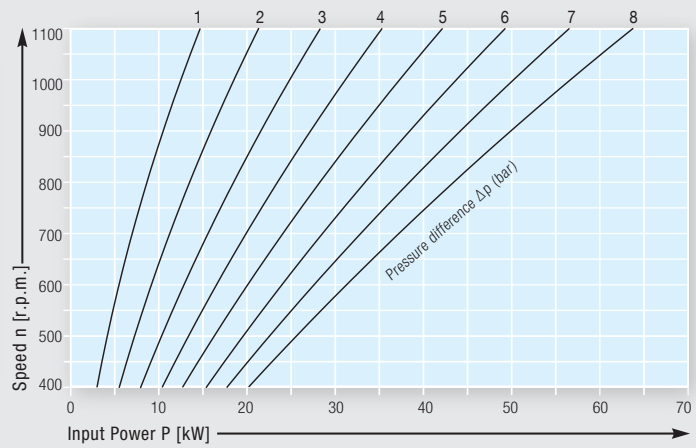

For non viscous liquids with viscosities up to about 12cSt, such as Diesel and gasoline fuels.