

FPO CH 100-1135
SELF PRIMING VANE PUMP

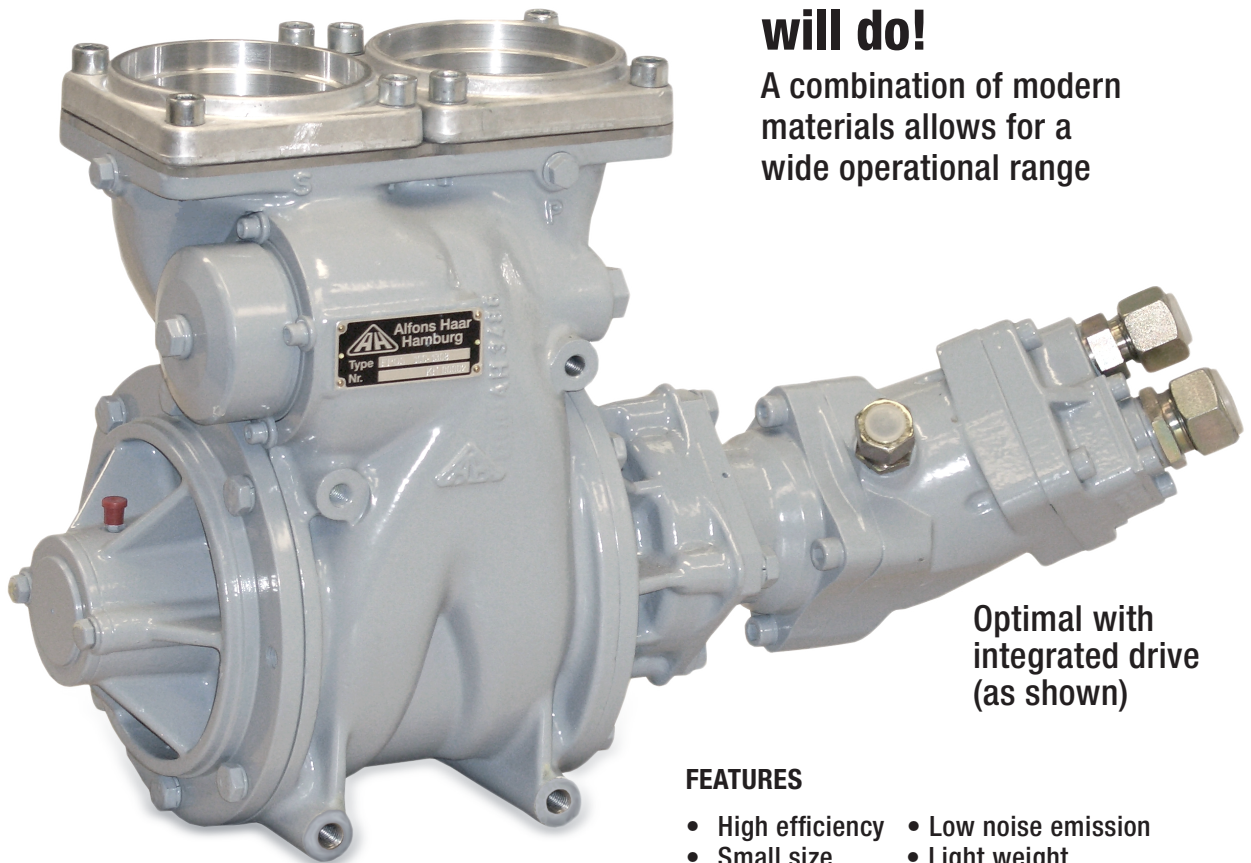

VANE PUMP FOR CHEMICAL PRODUCTS*

Up to 1.450 l/min with $\Delta p=8$ bar



**Not only
stainless steel
will do!**

A combination of modern materials allows for a wide operational range

Optimal with
integrated drive
(as shown)

Ex II 2G cT3 CE certified.
Operation without a flame arrester is possible in compliance with the certified ATEX conditions.

* According to chemical resistance list

FEATURES

- High efficiency
- Low noise emission
- Small size
- Light weight

By current modelling using numerical methods

- Dry suction capability
- Excellent lifetime
- PTO or integrated hydraulic drive

FPO CH 100-1135

SELF PRIMING VANE PUMP



DIMENSIONS

FPO... 100-1135

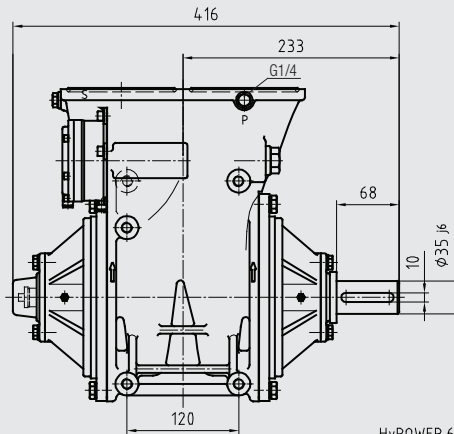

FPO... 100-1138

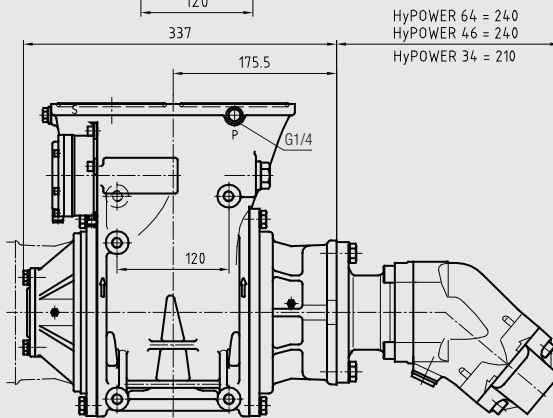

FPO G 100-

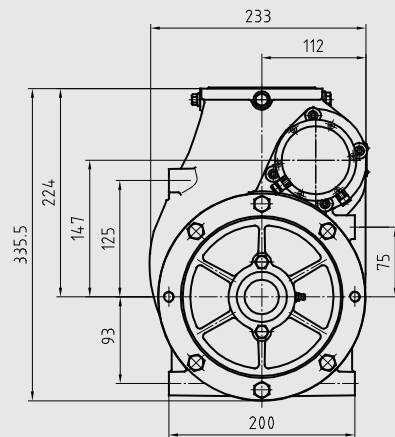

FLOW RATE

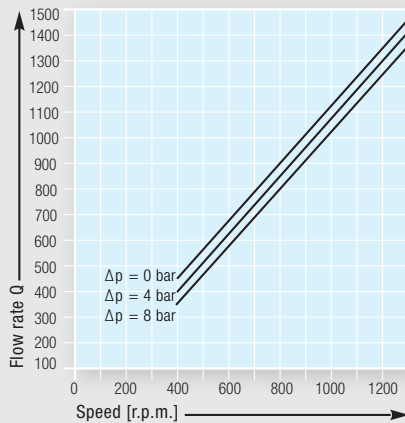

POWER CONSUMPTION

